

# TW4027

## TW4027 Low Current GPS Antenna

Frequency Coverage: GPS L1

### Overview

The TW4027 is a very low power, compact GNSS antenna covering the GPS-L1, frequency band. This antenna features an LNA with a nominal current consumption of just 2 mA, with constant performance from 2.5V to 16V supply voltage, and includes protection against close proximity L-Band transmitting antennas such as Iridium® and Globalstar™.

The TW4027 has among the lowest power consumption available, yet still provides 21 dB nominal gain and an excellent Noise Figure.

The TW4027 patch has 40% wider bandwidth for better axial ratio and has 15 kV ESD circuit protection. The LNA has a +/- 10 MHz bandwidth that covers the full GPS-L1 signal plus the SBAS (WAAS /EGNOS/MSAS) frequency band (1572.5 to 1578 MHz).

It is housed in a compact IP68 magnetic mount enclosure. The antenna can be ordered without the magnet. In such cases, the magnet is replaced with a plastic plug to provide a smooth under surface, with the option of ordering it with or without 1.1 mm thick doublesided VHB tape on the bottom.



### Applications

- Battery operated monitoring
- Covert Surveillance
- Fleet management and asset tracking
- Satcom based AVL solutions

### Features

- Nominal 2 mA current draw
- Invariant response, 2.5 to 16 VDC Supply
- Low Noise 1.0 dB typ.
- Axial ratio: 4 dB max.
- High-gain: 24 dB typ.
- IP68 weather proof housing

### Benefits

- Longer battery life
- Excellent signal-to-noise ratio
- CE RED, REACH, and RoHS compliant
- Ideal for harsh environments
- Excellent out-of-band signal rejection

**About Calian:** With global headquarters and manufacturing in Ottawa, Canada, Calian is a leading manufacturer of high-precision antennas and components for Global Navigation Satellite System (GNSS) applications. Calian's mission is to support the needs of a new generation of positioning systems by delivering unprecedented antenna precision at competitive prices. Learn more at [www.calian.com](http://www.calian.com)

Revision: 202407

Contact us:  
[info@tallysman.com](mailto:info@tallysman.com)  
T: +1 613 591-3131

# TW4027 Low Current GPS Antenna

Frequency Coverage: GPS L1

## Antenna

Technology Single-feed RHCP ceramic patch

		Gain	Axial Ratio
		dBic typ. at Zenith	dB at Zenith
<b>GNSS</b>			
GPS / QZSS	L1	4.5	≤ 4
	L2	-	-
	L5	-	-
GLONASS	G1	-	-
	G2	-	-
	G3	-	-
Galileo	E1	-	-
	E5A	-	-
	E5B	-	-
	E6	-	-
BeiDou	B1	-	-
	B2b	-	-
	B2a	-	-
	B3	-	-
IRNSS / NavIC	L5	-	-
QZSS	L6	-	-
L-Band Services (1525 MHz - 1559 MHz)		-	-
<b>Satellite Communications</b>			
Iridium		-	-
Globalstar		-	-
<b>Other</b>			
Axial Ratio at 10°	-	Efficiency	-
PC Variation	-		

## Mechanicals

Size	38.6 mm (sq.) x 14.7 mm (h.)
Weight	34 g (without cable)
Radome	LEXAN™ EXL9330
Mount	Adhesive, magnetic
Available Connectors	Please see ordering guide

## Environmental

Operating Temperature	-40 °C to +85 °C
Storage Temperature	-55 °C to +95 °C
Vibration	MIL-STD-810-G - Test Method 514.6
Shock	MIL-STD-810-G - Test Method 516.6
Salt Fog	MIL-STD-810-F - Test Method 509.5
IP Rating	IP68
Compliance	IPC-A-610, FCC, RED / CE Mark, RoHS, REACH

## Warranty

Parts and Labour	3-year standard warranty
------------------	--------------------------

## Low Noise Amplifier (LNA) - Measured at 3V and 25°C

Frequency Bandwidth	Out of Band Rejection
1575.42 MHz ± 10 MHz	> 32 dB @ < 1500 MHz > 25 dB @ < 1550 MHz > 35 dB @ > 1640 MHz

Architecture	Non pre-filtered
Gain	24 dB typ., 21 dB min.
Noise Figure	1 dB typ.
VSWR	< 1.5:1 typ., 1.8:1 max.
Supply Voltage Range	2.5 to 16 VDC nominal (12 VDC rec. max.)
Supply Current	2 mA typ.
ESD Circuit Protection	15 kV air discharge
P 1dB Output	-
Group Delay	-
PCO	-

## Mechanical Diagram

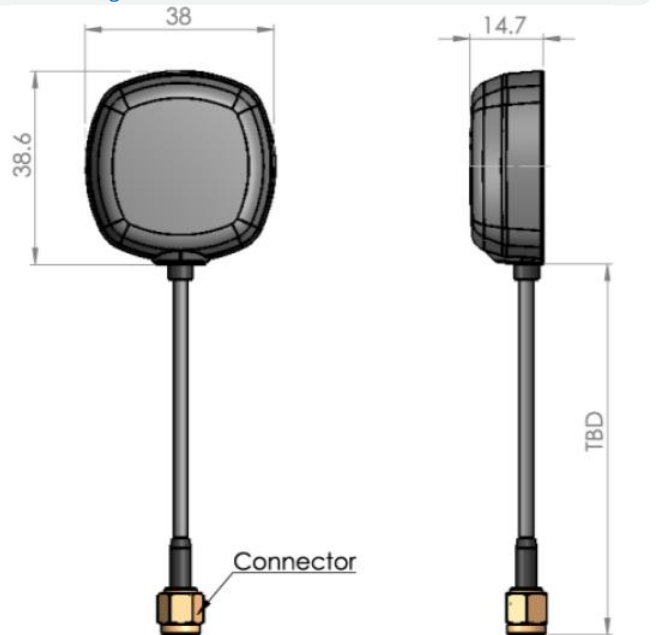

## Ordering Information

**Part Number** 33-4027-xx-yyyy

Where xx = connector type and yyyy = cable length in mm

Please refer to our **Ordering Guide** to review available radomes and connectors at: <https://www.tallysman.com/resource/tallysman-ordering-guide/>