

TW3010



Permanent-Mount GPS-L1 Antenna

Frequency Coverage: GPS L1

The TW3010 is a professional-grade, permanent-mount GPS-L1 antenna, specially designed for precision tracking and timing applications.

The TW3010 features a custom high performance, wide band patch element, a 28 dB gain LNA stage and a high-rejection out-of-band SAW filter. It provides ± 10 MHz bandwidth centred on 1575.42 MHz and covers the GPS-L1, and SBAS (WAAS/EGNOS/MSAS) signals. It provides great axial ratio, excellent circular polarized signal reception, strong multipath rejection and deep out-of-band signal rejection.

The TW3010 is housed in a permanent-mount industrial-grade weatherproof enclosure. Optional components include a 10 cm ground plane (provided for optimal performance), an L-bracket mount (P/N 23-0040-0), or a pipe mount (P/N 23-0065-0).



Applications

- Mission-critical GPS tracking and timing
- Precision agriculture, mining, and construction
- Law enforcement and public safety
- Fleet management and asset tracking
- Avionics

Features

- Great axial ratio
- Low noise LNA (1.8 dB typ.)
- High-rejection SAW filter
- High-gain LNA (28 dB typ.)
- Low current (9 mA typ.)
- ESD circuit protection (15 kV)
- Wide supply voltage range (2.5 to 16 VDC)
- IP69K weatherproof housing

Benefits

- Excellent multipath rejection
- Increase system accuracy
- Excellent signal-to-noise ratio
- Deep out-of-band signal rejection
- Ideal for harsh environments
- CE RED, RoHS, and REACH compliant

About Calian: With global headquarters and manufacturing in Ottawa, Canada, Calian is a leading manufacturer of high-precision antennas and components for Global Navigation Satellite System (GNSS) applications. Calian's mission is to support the needs of a new generation of positioning systems by delivering unprecedented antenna precision at competitive prices. Learn more at www.calian.com

Revision: 202407

Contact us:
info@tallysman.com
T: +1 613 591-3131

Permanent-Mount GPS-L1 Antenna

Frequency Coverage: GPS L1

Antenna

Technology Single-feed RHCP ceramic patch

		Gain	Axial Ratio
		dBic typ. at Zenith	dB at Zenith
GNSS			
GPS / QZSS	L1	4.0	≤ 4
	L2	-	-
	L5	-	-
GLONASS	G1	-	-
	G2	-	-
	G3	-	-
Galileo	E1	-	-
	E5A	-	-
	E5B	-	-
	E6	-	-
BeiDou	B1	-	-
	B2b	-	-
	B2a	-	-
	B3	-	-
IRNSS / NavIC	L5	-	-
QZSS	L6	-	-
L-Band Services (1539 MHz - 1559 MHz)		-	-
Satellite Communications			
Iridium		-	-
Globalstar		-	-
Other			
Axial Ratio at 10°	-	Efficiency	-
PCV $\Phi > 15^\circ$	-	PCO	-

Mechanicals

Size 66.5 mm (dia.) x 21 mm (h.)
 Weight 150 g
 Radome LEXAN™ EXL9330, Base: Zamac Metal
 Mount Through-hole (100 mm ground plane provided)
 Available Connectors Please refer to ordering guide

Environmental

Operating Temperature -40 °C to +85 °C
 Storage Temperature -55 °C to +95 °C
 Vibration MIL-STD-810-E - Test Method 514.5
 Shock MIL-STD-810-G - Test Method 516.6
 Salt Fog MIL-STD-810-F - Test Method 509.5
 Other Tests Hail, Humidity, Dust, Rain, Sand, Solar
 IP Rating IP69K
 Compliance IPC-A-610, FCC, CE RED, RoHS, REACH

Warranty

Parts and Labour 3-year standard warranty

Low Noise Amplifier (LNA) - Measured at 3V and 25°C

Frequency Bandwidth	Out of Band Rejection
Lower Band	-
L-Band Corr.	-
Upper Band	1575.42 MHz ± 10 MHz
	> 40 dB @ < 1560 MHz > 26 dB @ > 1600 MHz > 48 dB @ > 1620 MHz

Architecture Non pre-filtered
 Gain 28 dB typ., 26 dB min.
 Noise Figure 1.8 dB typ.
 VSWR < 1.5:1 typ., 1.8:1 max.
 Supply Voltage Range 2.5 to 16 VDC nominal, up to 50mV p-p ripple
 Supply Current 9 mA typ.
 ESD Circuit Protection 15 kV air discharge
 P 1dB Output 4 dBm typ.
 Group Delay 34 ns typ. @ (1570.42 - 1580.42 MHz)

Mechanical Diagram - Units in 'mm' or 'inches' where specified

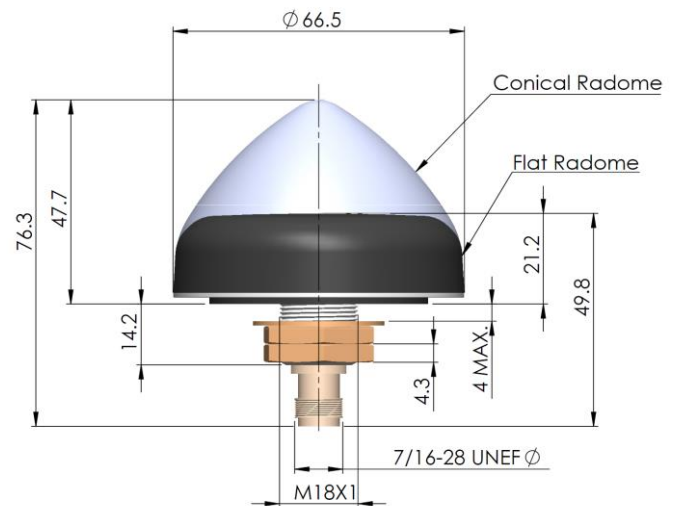

Ordering Information

Part Number 33-3010-xx-yy-zzzz
 where xx = connector type, yy = shape and colour of radome, and zzzz = cable length in mm

Please refer to our **Ordering Guide** to review available radomes and connectors at:
<https://www.tallysman.com/resource/tallysman-ordering-guide/>